

(M12X90mm expansive bolt)

### Installation Manual :

- 1 The  $\varnothing 25\text{mm}$  PVC tube for AC 220V or AC 110V Power  $M12 \varnothing 0\text{mm}$  .
- 2 The tube for connecting two equipments in the same passage wire (16 X  $\varnothing 0.5\text{mm}$ ) .
- 3 The tube for RS485 wire (2 X  $\varnothing 0.5\text{mm}$ ) , TCP/IP wire (8 core) , Manually opening the turnstile wire (4 X  $\varnothing 0.3\text{mm}$ ) . The signal wire length should be less than 100m .
- 4 It is PCB board part .
- 5 Fixing the equipment with M12 X 90mm expansive bolt .

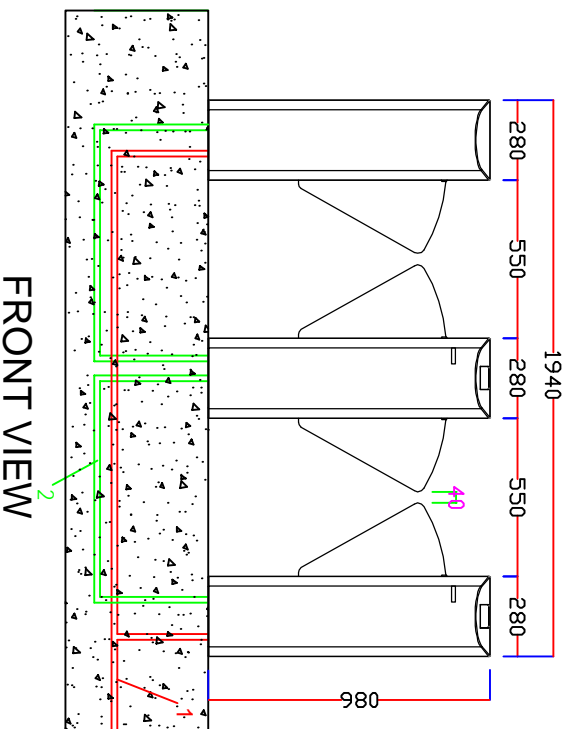

FRONT VIEW

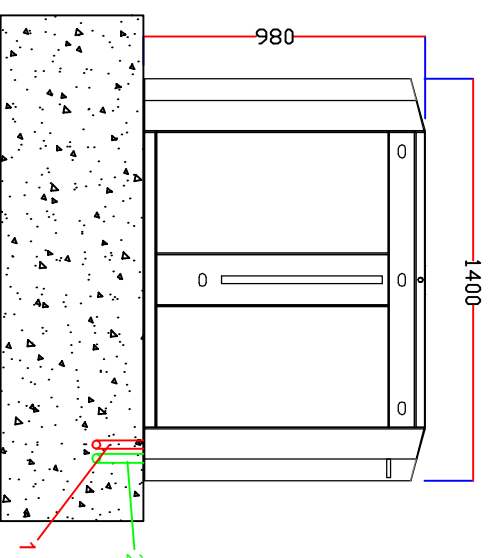

SIDE VIEW

### SCALE-N-TS

GROUP :- Smart Security Flap Barriers

PRODUCT :- Dual Lane Flap Barrier-Normal Lane

MODEL NO:-TDB-201-S+TDB-201-D

This drawing is the soul property of (TAS) Do not copy/reproduce /share with others without our permission.

REV	DATE	DESCRIPTION	DRAWN BY	APPROVED BY	DATE	DRAWN BY	CHECKED BY	APPROVED BY
00	06-10-18	ISSUED FOR APPROVAL	SOHRAB KHAN	MOHD.AMIL	06-10-18	SOHRAB KHAN	MOHD.AMIL	KAPIL SACHDEV
PRO NO :- 3879					DRAWING NO :- GA-372 (PRO 3879) 2*TDB-201-S+TDB-201-D			